

# R100030G1 Charging Module

## User Manual

**Issue** 09  
**Date** 2024-01-05



**Copyright © Huawei Technologies Co., Ltd. 2024. All rights reserved.**

No part of this document may be reproduced or transmitted in any form or by any means without prior written consent of Huawei Technologies Co., Ltd.

## **Trademarks and Permissions**



HUAWEI and other Huawei trademarks are trademarks of Huawei Technologies Co., Ltd.

All other trademarks and trade names mentioned in this document are the property of their respective holders.

## **Notice**

The purchased products, services and features are stipulated by the contract made between Huawei and the customer. All or part of the products, services and features described in this document may not be within the purchase scope or the usage scope. Unless otherwise specified in the contract, all statements, information, and recommendations in this document are provided "AS IS" without warranties, guarantees or representations of any kind, either express or implied.

The information in this document is subject to change without notice. Every effort has been made in the preparation of this document to ensure accuracy of the contents, but all statements, information, and recommendations in this document do not constitute a warranty of any kind, express or implied.

## **Huawei Technologies Co., Ltd.**

Address: Huawei Industrial Base  
Bantian, Longgang  
Shenzhen 518129  
People's Republic of China

Website: <https://e.huawei.com>

# Security Declaration

## Product Lifecycle

Huawei's regulations on product lifecycle are subject to the *Product End of Life Policy*. For details about this policy, visit the following web page:

<https://support.huawei.com/ecolumnsweb/en/warranty-policy>

## Vulnerability

Huawei's regulations on product vulnerability management are subject to the *Vul. Response Process*. For details about this process, visit the following web page:

<https://www.huawei.com/en/psirt/vul-response-process>

For vulnerability information, enterprise customers can visit the following web page:

<https://securitybulletin.huawei.com/enterprise/en/security-advisory>

## Preconfigured Digital Certificate

The digital certificates preconfigured on Huawei devices are subject to the *Rights and Responsibilities of Preconfigured Digital Certificates on Huawei Devices*. For details about this document, visit the following web page:

<https://support.huawei.com/enterprise/en/bulletins-service/ENEWS2000015789>

## Huawei Enterprise End User License Agreement

This agreement is the end user license agreement between you (an individual, company, or any other entity) and Huawei for the use of the Huawei Software. Your use of the Huawei Software will be deemed as your acceptance of the terms mentioned in this agreement. For details about this agreement, visit the following web page:

<https://e.huawei.com/en/about/eula>

## Lifecycle of Product Documentation

Huawei after-sales user documentation is subject to the *Product Documentation Lifecycle Policy*. For details about this policy, visit the following web page:

<https://support.huawei.com/enterprise/en/bulletins-website/ENEWS2000017761>

# About This Document

## Purpose

This document describes the product in terms of the overview, transportation, storage, installation, maintenance, and technical specifications. Before operating the charging module, ensure that you are familiar with its features, functions, and safety precautions provided in this document.






Figures provided in this document are for reference only.

## Intended Audience

This document is intended for charging module operation personnel and qualified electrical technicians.

## Symbol Conventions

The symbols that may be found in this document are defined as follows.

Symbol	Description
	Indicates a hazard with a high level of risk which, if not avoided, will result in death or serious injury.
	Indicates a hazard with a medium level of risk which, if not avoided, could result in death or serious injury.
	Indicates a hazard with a low level of risk which, if not avoided, could result in minor or moderate injury.
	Indicates a potentially hazardous situation which, if not avoided, could result in equipment damage, data loss, performance deterioration, or other unanticipated results. NOTICE is used to address practices not related to personal injury.
	Supplements the important information in the main text. NOTE is used to address information not related to personal injury, equipment damage, and environment deterioration.

## Change History

Changes between document issues are cumulative. The latest document issue contains all the changes made in previous issues.

### Issue 09 (2024-01-05)

Updated the alarm indicator (yellow) in [2.4.2 Indicators](#).

### Issue 08 (2023-07-28)

Updated the ESD requirements in [1.2 Electrical Safety](#).

Updated the fault description and handling measures of fault E00 in [5.2 Troubleshooting](#).

Updated the tools in [5.3 Replacement](#).

### Issue 07 (2023-03-15)

Updated [1 Safety Information](#).

### Issue 06 (2023-01-15)

Updated the figures and crimping description in [4.4 Cable Connection](#).

Added the troubleshooting method for power indicator off and updated the troubleshooting method for the CAN communication fault (communication interruption between the charging module and external devices) in [5.2 Troubleshooting](#).

Added [6.6 Other Characteristics](#), which includes the EMC, surge protection, and reliability characteristics.

Updated the insulated tools in the figures.

### Issue 05 (2021-11-16)

Added descriptions about the module ports, input connector directions, and product replacement.

Added descriptions about the status code display and error codes, and marked tolerances in the figure showing the installation clearances.

### Issue 04 (2021-08-06)

Optimized the illustration about the input connector directions.

### Issue 03 (2021-01-18)

Updated the technical specifications, button operations, and power cable temperature resistance.

## **Issue 02 (2020-09-03)**

Updated some parameters in section "Technical Specifications" and updated section "Button Operations."

## **Issue 01 (2020-05-10)**

This issue is the first official release.

---

# Contents

---

<b>About This Document.....</b>	<b>iii</b>
<b>1 Safety Information.....</b>	<b>1</b>
1.1 Personal Safety.....	2
1.2 Electrical Safety.....	4
1.3 Environment Requirements.....	6
1.4 Mechanical Safety.....	8
<b>2 Product Description.....</b>	<b>10</b>
2.1 Overview.....	10
2.2 Key Features.....	12
2.3 Appearance.....	13
2.4 Display Panel.....	13
2.4.1 Display Panel.....	13
2.4.2 Indicators.....	14
2.4.3 Nixie Tube Display.....	15
2.4.4 Button Operations.....	17
2.5 Module Ports.....	20
2.6 Input and Output Connectors.....	21
2.6.1 Input Connector.....	21
2.6.2 Output Connector.....	22
<b>3 Transportation and Storage.....</b>	<b>25</b>
<b>4 Installation.....</b>	<b>26</b>
4.1 Installation Preparations.....	26
4.2 Installation Requirements.....	28
4.3 Installing a Charging Module.....	29
4.4 Cable Connection.....	31
4.4.1 Connecting DC Output Power Cables.....	31
4.4.2 Connecting AC Input Power Cables.....	33
4.5 Powering On the Charging Module and Setting Parameters.....	34
<b>5 Maintenance.....</b>	<b>35</b>
5.1 Routine Maintenance.....	35
5.2 Troubleshooting.....	35

---

5.3 Replacement.....	42
<b>6 Technical Specifications.....</b>	<b>46</b>
6.1 Structure.....	46
6.2 Environment.....	46
6.3 Input.....	47
6.4 Output.....	47
6.5 Protection.....	48
6.6 Other Characteristics.....	48
6.7 Characteristic Curves.....	49
<b>A Acronyms and Abbreviations.....</b>	<b>51</b>

# 1 Safety Information

---

## Statement

**Before transporting, storing, installing, operating, using, and/or maintaining the equipment, read this document, strictly follow the instructions provided herein, and follow all the safety instructions on the equipment and in this document.** In this document, "equipment" refers to the products, software, components, spare parts, and/or services related to this document; "the Company" refers to the manufacturer (producer), seller, and/or service provider of the equipment; "you" refers to the entity that transports, stores, installs, operates, uses, and/or maintains the equipment.

The **Danger, Warning, Caution, and Notice** statements described in this document do not cover all the safety precautions. You also need to comply with relevant international, national, or regional standards and industry practices. **The Company shall not be liable for any consequences that may arise due to violations of safety requirements or safety standards concerning the design, production, and usage of the equipment.**

The equipment shall be used in an environment that meets the design specifications. Otherwise, the equipment may be faulty, malfunctioning, or damaged, which is not covered under the warranty. The Company shall not be liable for any property loss, personal injury, or even death caused thereby.

Comply with applicable laws, regulations, standards, and specifications during transportation, storage, installation, operation, use, and maintenance.

Do not perform reverse engineering, decompilation, disassembly, adaptation, implantation, or other derivative operations on the equipment software. Do not study the internal implementation logic of the equipment, obtain the source code of the equipment software, violate intellectual property rights, or disclose any of the performance test results of the equipment software.

**The Company shall not be liable for any of the following circumstances or their consequences:**

- The equipment is damaged due to force majeure such as earthquakes, floods, volcanic eruptions, debris flows, lightning strikes, fires, wars, armed conflicts, typhoons, hurricanes, tornadoes, and other extreme weather conditions.
- Operation beyond the conditions specified in this document

- Installation or use in environments that do not comply with international, national, or regional standards
- Installation or use by unqualified personnel
- Failure to follow the operation instructions or safety precautions on the product or in this document
- Unauthorized modifications to the product or software code or removal of the product
- Damage caused during transportation by the customer or a third party authorized by the customer
- Storage conditions that do not meet the requirements specified in this document
- Failure to comply with local laws, regulations, and related standards due to the materials and tools prepared by the customer
- The equipment is damaged due to your or a third party's negligence, intentional breach, gross negligence, or improper operations, or other reasons not related to the Company.
- The equipment run beyond the conditions specified in this document
- The equipment run beyond the specified parameter ranges.
- The warranty expired and is not extended.
- The charging module cannot prevent battery reverse connection, which needs to be detected by the charging facility (charger). The module failure caused by battery reverse connection is not covered under the warranty.
- When installing the charging module, ensure that all mounting holes on the module panel are secured by screws. The module failure caused by loose connection is not covered under the warranty.

## 1.1 Personal Safety

---

 **DANGER**

Ensure that power is off during installation. Do not install or remove a cable with power on. Transient contact between the core of the cable and the conductor will generate electric arcs or sparks, which may cause a fire or personal injury.

---

---

 **DANGER**

Non-standard and improper operations on the energized equipment may cause fire or electric shocks, resulting in property damage, personal injury, or even death.

---

---

 **DANGER**

Before operations, remove conductive objects such as watches, bracelets, bangles, rings, and necklaces to prevent electric shocks.

---

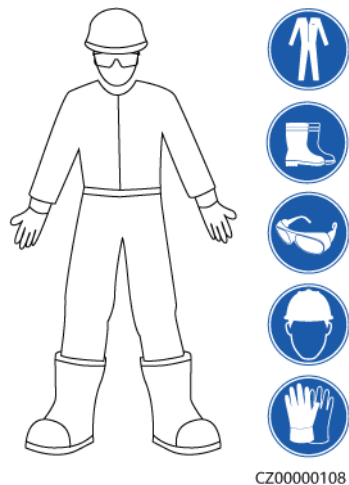
**⚠ DANGER**

During operations, use dedicated insulated tools to prevent electric shocks or short circuits. The insulation and voltage resistance must comply with local laws, regulations, standards, and specifications.

**⚠ WARNING**

During operations, wear personal protective equipment such as protective clothing, insulated shoes, goggles, safety helmets, and insulated gloves.

**Figure 1-1** Personal protective equipment



## General Requirements

- Do not stop protective devices. Pay attention to the warnings, cautions, and related precautionary measures in this document and on the equipment.
- If there is a likelihood of personal injury or equipment damage during operations, immediately stop, report the case to the supervisor, and take feasible protective measures.
- Do not power on the equipment before it is installed or confirmed by professionals.
- Do not touch the power supply equipment directly or with conductors such as damp objects. Before touching any conductor surface or terminal, measure the voltage at the contact point to ensure that there is no risk of electric shock.
- Do not touch a running fan with your hands, components, screws, tools, or boards. Otherwise, personal injury or equipment damage may occur.
- In the case of a fire, immediately leave the building or the equipment area and activate the fire alarm or call emergency services. Do not enter the affected building or equipment area under any circumstances.

## Personnel Requirements

- Only professionals and trained personnel are allowed to operate the equipment.
  - Professionals: personnel who are familiar with the working principles and structure of the equipment, trained or experienced in equipment operations and are clear of the sources and degree of various potential hazards in equipment installation, operation, maintenance
  - Trained personnel: personnel who are trained in technology and safety, have required experience, are aware of possible hazards on themselves in certain operations, and are able to take protective measures to minimize the hazards on themselves and other people
- Personnel who plan to install or maintain the equipment must receive adequate training, be able to correctly perform all operations, and understand all necessary safety precautions and local relevant standards.
- Only qualified professionals or trained personnel are allowed to install, operate, and maintain the equipment.
- Only qualified professionals are allowed to remove safety facilities and inspect the equipment.
- Personnel who will perform special tasks such as electrical operations, working at heights, and operations of special equipment must possess the required local qualifications.
- Only authorized professionals are allowed to replace the equipment or components (including software).
- Only personnel who need to work on the equipment are allowed to access the equipment.

## 1.2 Electrical Safety

---

 **DANGER**

Before connecting cables, ensure that the equipment is intact. Otherwise, electric shocks or fires may occur.

---

---

 **DANGER**

Non-standard and improper operations may result in fire or electric shocks.

---

---

 **DANGER**

Prevent foreign matter from entering the equipment during operations. Otherwise, equipment damage, load power derating, power failure, or personal injury may occur.

---

## General Requirements

- Follow the procedures described in the document for installation, operation, and maintenance. Do not reconstruct or alter the equipment, add components, or change the installation sequence without permission.
- Before installing or removing power cables, turn off the switches of the equipment and its upstream and downstream switches.
- If any liquid is detected inside the equipment, disconnect the power supply immediately and do not use the equipment.
- Before performing operations on the equipment, check that all tools meet the requirements and record the tools. After the operations are complete, collect all of the tools to prevent them from being left inside the equipment.
- Before installing power cables, check that cable labels are correct and cable terminals are insulated.
- When installing the equipment, use a torque tool of a proper measurement range to tighten the screws. When using a wrench to tighten the screws, ensure that the wrench does not tilt and the torque error does not exceed 10% of the specified value.
- Ensure that all slots are installed with boards or filler panels. Avoid hazards caused by hazardous voltages or energy on boards. Ensure that the air channel is normal, control electromagnetic interference, and prevent dust and other foreign objects on the backplane, baseplate, and boards.
- After the installation is complete, ensure that protective cases, insulation tubes, and other necessary items for all electrical components are in position to avoid electric shocks.
- If the power supply to the equipment is permanently connected, install an easily accessible disconnecter at the exterior of the device.
- Before connecting the power supply, ensure that electrical connections are correct.
- If the equipment has multiple inputs, disconnect all the inputs before operating the equipment.
- Before maintaining a downstream electrical or power distribution device, turn off the output switch on the power supply equipment.
- During equipment maintenance, attach "Do not switch on" labels near the upstream and downstream switches or circuit breakers as well as warning signs to prevent accidental connection. The equipment can be powered on only after troubleshooting is complete.
- If fault diagnosis and troubleshooting need to be performed after power-off, take the following safety measures: Disconnect the power supply. Check whether the equipment is live. Install a ground cable. Hang warning signs and set up fences.
- Check equipment connections periodically, ensuring that all screws are securely tightened.
- Do not scrawl, damage, or block any labels or nameplates on the equipment. Promptly replace labels that have worn out.
- Do not remove the warranty label or barcode from the charging module. Otherwise, product warranty will be forfeited.
- Do not modify or damage the nameplate on the back of the charging module because it contains important product information.

- Do not use solvents such as water, alcohol, or oil to clean electrical components inside or outside of the equipment.

## Grounding Requirements

- Ensure that the grounding impedance of the equipment complies with local electrical standards.
- Do not operate the equipment in the absence of a properly installed ground conductor.
- Do not damage the ground conductor.
- If high touch current may occur on the equipment, ground the protective ground terminal on the equipment enclosure before connecting the power supply; otherwise, electric shock as a result of touch current may occur.

## ESD Requirements

---

### NOTICE

The static electricity generated by human bodies may damage the electrostatic-sensitive components on boards, for example, the large-scale integrated (LSI) circuits.

- When holding a board or a module with exposed terminals, hold its edge without touching any components or its terminals. Do not touch the components or terminals with bare hands.

## 1.3 Environment Requirements

---

### DANGER

Do not expose the equipment to flammable or explosive gas or smoke. Do not perform any operation on the equipment in such environments.

---

### DANGER

Do not store any flammable or explosive materials in the equipment area.

---

### DANGER

Do not place the equipment near heat sources or fire sources, such as smoke, candles, heaters, or other heating devices. Overheat may damage the equipment or cause a fire.

---

---

 **WARNING**

Install the equipment in an area far away from liquids. Do not install it under areas prone to condensation, such as under water pipes and air exhaust vents, or areas prone to water leakage, such as air conditioner vents, ventilation vents, or feeder windows of the equipment room. Ensure that no liquid enters the equipment to prevent faults or short circuits.

---

---

 **WARNING**

To prevent damage or fire due to high temperature, ensure that the ventilation vents or heat dissipation systems are not obstructed or covered by other objects while the equipment is running.

---

## General Requirements

- Ensure that the equipment is stored in a clean, dry, and well ventilated area with proper temperature and humidity and is protected from dust and condensation.
- Keep the installation and operating environments of the equipment within the allowed ranges. Otherwise, its performance and safety will be compromised.
- Do not install, use, or operate outdoor equipment and cables (including but not limited to moving equipment, operating equipment and cables, inserting connectors to or removing connectors from signal ports connected to outdoor facilities, working at heights, performing outdoor installation, and opening doors) in harsh weather conditions such as lightning, rain, snow, and level 6 or stronger wind.
- Do not install the equipment in an environment with dust, smoke, volatile or corrosive gases, infrared and other radiations, organic solvents, or salty air.
- Do not install the equipment in an environment with conductive metal or magnetic dust.
- Do not install the equipment in an area conducive to the growth of microorganisms such as fungus or mildew.
- Do not install the equipment in an area with strong vibration, noise, or electromagnetic interference.
- When installing the equipment, ensure that the installation base is solid enough to bear the weight of the equipment.
- After installing the equipment, remove the packing materials such as cartons, foam, plastics, and cable ties from the equipment area.

## 1.4 Mechanical Safety

---

 **WARNING**

Ensure that all necessary tools are ready and inspected by a professional organization. Do not use tools that have signs of scratches or fail to pass the inspection or whose inspection validity period has expired. Ensure that the tools are secure and not overloaded.

---

---

 **WARNING**

Before installing equipment in a cabinet, ensure that the cabinet is securely fastened with a balanced center of gravity. Otherwise, tipping or falling cabinets may cause bodily injury and equipment damage.

---

---

 **WARNING**

When pulling equipment out of a cabinet, be aware of unstable or heavy objects in the cabinet to prevent injury.

---

---

 **WARNING**

Do not drill holes into the equipment. Doing so may affect the sealing performance and electromagnetic containment of the equipment and damage components or cables inside. Metal shavings from drilling may short-circuit boards inside the equipment.

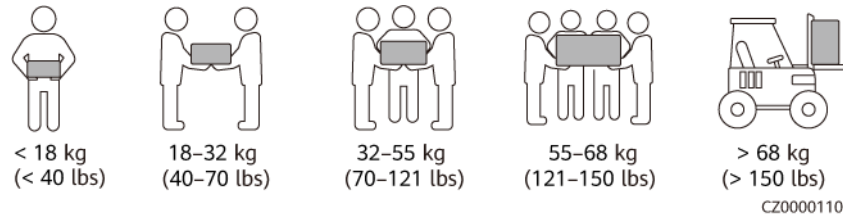
---

### General Requirements

- Repaint any paint scratches caused during equipment transportation or installation in a timely manner. Equipment with scratches cannot be exposed for an extended period of time.
- Do not perform operations such as arc welding and cutting on the equipment without evaluation by the Company.
- When performing operations over the top of the equipment, take measures to protect the equipment against damage.
- Use correct tools and operate them in the correct way.

### Moving Heavy Objects

- Be cautious to prevent injury when moving heavy objects.



- If multiple persons need to move a heavy object together, determine the manpower and work division with consideration of height and other conditions to ensure that the weight is equally distributed.
- If two persons or more move a heavy object together, ensure that the object is lifted and landed simultaneously and moved at a uniform pace under the supervision of one person.
- Wear personal protective gears such as protective gloves and shoes when manually moving the equipment.
- To move an object by hand, approach to the object, squat down, and then lift the object gently and stably by the force of the legs instead of your back. Do not lift it suddenly or turn your body around.
- Move or lift the equipment by holding its handles or lower edges. Do not hold the handles of modules that are installed in the equipment.
- Do not quickly lift a heavy object above your waist. Place the object on a workbench that is half-waist high or any other appropriate place, adjust the positions of your palms, and then lift it.
- Move a heavy object stably with balanced force at an even and low speed. Put down the object stably and slowly to prevent any collision or drop from scratching the surface of the equipment or damaging the components and cables.
- When moving a heavy object, be aware of the workbench, slope, staircase, and slippery places. When moving a heavy object through a door, ensure that the door is wide enough to move the object and avoid bumping or injury.
- When transferring a heavy object, move your feet instead of turning your waist around. When lifting and transferring a heavy object, ensure that your feet point to the target direction of movement.
- When transporting the equipment using a pallet truck, ensure that the forks are properly positioned so that the equipment does not topple. Before moving the equipment, secure it to the pallet truck using ropes. When moving the equipment, assign dedicated personnel to take care of it.

# 2 Product Description

## 2.1 Overview

### Function

The R100030G1 is an AC-DC charging module that features high efficiency and power density. It supports three-phase four-wire input of 260–485 V AC (line voltage). The output voltage ranges from 200 V DC to 1000 V DC, and the rated output power is 30 kW.

The charging module uses the isolated controller area network (CAN) communications port and communicates with the system monitoring module over the CAN protocol. You can set the output voltage mode of the charging module on the system monitoring module and perform voltage adjustment, current limiting, and startup or shutdown for the charging module.

Figure 2-1 Model number

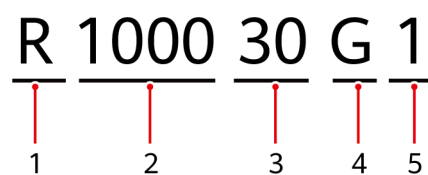


Table 2-1 Model number description

No.	Meaning	Description
1	Module series name	Rectifier
2	Output voltage	1000 V DC
3	Rated output current	30 A
4	Efficiency type	G (Green), green efficient module
5	Module version	1

## Working Mode

The charging module supports low-voltage and high-voltage modes and provides full power output to be compatible with various vehicle models and ensure fast charging. The charging module can be set to silent mode or standard mode according to noise requirements.

**Table 2-2** Working mode

Voltage Mode	Noise Mode	
	Silent Mode	Standard Mode
Automatic switching	Supported	Supported
Manual switching to high voltage	Supported	Supported
Manual switching to low voltage	Supported	Supported

The charging module works in automatic switching mode by default. It automatically switches to the low-voltage or high-voltage mode based on the output port voltage, preset voltage, or battery voltage reported by the monitoring module.

The automatic switching mode of the charging module can be set to any of the following:

1. Automatic switching based on the module output port voltage (factory default)
2. Automatic switching based on the preset voltage
3. Automatic switching based on the battery voltage reported by the monitoring module

Manual switching is also supported. You can manually switch to the low-voltage or high-voltage mode on the system monitoring module.

- Low-voltage mode: 200–506 V DC output
- High-voltage mode: 200–1000 V DC output

The charging module works in standard mode by default. You can set it to silent mode on the system monitoring module based on the noise reduction requirements.

- Silent mode: Multiple levels (55 dB max, 60 dB max, and 65 dB max) are provided. In silent mode, the module output power is derated accordingly.
- Standard mode: The rated output power is 30 kW.

## Display Panel

The display panel of the charging module consists of three indicators, three nixie tubes, and two buttons.

- The indicators show the running status of the charging module.
- The nixie tubes display the output voltage, output current, hardware address, group number, startup/shutdown status, software version, or error code of the charging module.
- The buttons allow you to set the output voltage, output current, hardware address, and group number, and to start or shut down the charging module.

 **NOTE**

If the hardware addresses of two charging modules are the same, an alarm is generated, indicating duplicate hardware addresses.

## Grouping and Address Allocation

- You can set the groups for charging modules on the system monitoring module. Charging modules in a group can automatically implement current sharing control.
- Software addresses are automatically allocated to the charging modules in a group to facilitate module identification. Note that the software address may be different from the slot number of the charging pile.
- The hardware address of a charging module can be set to stay consistent with the slot number of the charging pile. The charging module saves the hardware address upon power-off.

 **NOTE**

- The software address will be reallocated after adding, reducing, or replacing a charging module.
- If an alarm is generated indicating that the hardware address of the module is duplicate after the charging module is moved from one charging pile to another, reset the hardware address first and then the group number of that module. After the hardware address is modified, the group number is restored to the default value.

## 2.2 Key Features

- Wide input voltage range: 260–485 V AC
- Wide operating temperature range: –35°C to +75°C
- Rated output voltage: 1000 V DC
- Maximum output power: 30 kW
- Hot swappable
- Intelligent adjustment of fan speed
- CAN bus communication
- Alarm display on the LED and nixie tubes
- Voltage adjustment, current limiting, and current sharing
- Comprehensive protection
  - Ambient overtemperature/undertemperature protection
  - Input: overvoltage/undervoltage protection and three-phase imbalance protection
  - Output: overvoltage protection and short circuit protection

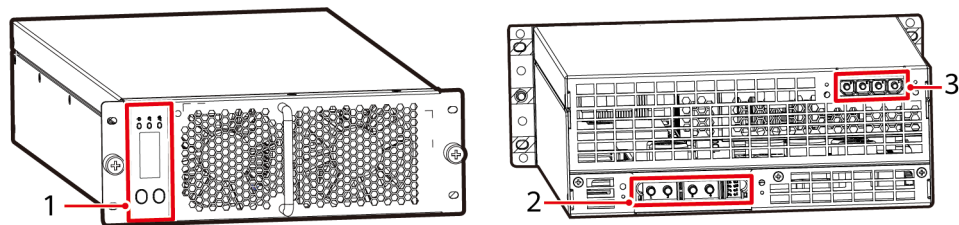
- Output backfeed isolation
- Grouping
  - Control of modules in different groups on the bus by the system monitoring module
  - Storage of group numbers and hardware addresses upon power-off

## 2.3 Appearance

### NOTICE

Do not remove the warranty label or barcode. Otherwise, the product warranty will be forfeited.

Figure 2-2 Charging module



MR04W10013

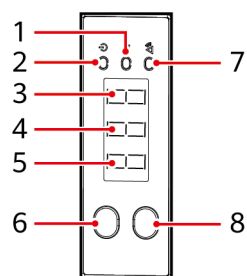
(1) Display panel

(2) DC output and signal ports (3) AC input ports

## 2.4 Display Panel

### 2.4.1 Display Panel

Figure 2-3 Display panel





MR04W10001


**Table 2-3** Display panel

No.	Item
1	Alarm indicator (yellow)
2	Power indicator (green)
3	Low-order nixie tube
4	Middle-order nixie tube
5	High-order nixie tube
6	Left button
7	Fault indicator (red)
8	Right button

## 2.4.2 Indicators

**Table 2-4** Charging module indicators

Indicator	Status	Description
Power indicator (green) 	Steady on	Normal: The charging module has AC input.
	Off	The charging module has no AC input.
	Blinking at 4 Hz	Querying in progress
	Blinking at 0.5 Hz	Module hibernation (standby)
Alarm indicator (yellow) 	Off	Normal: The charging module does not generate any protection alarms.

Indicator	Status	Description
	Steady on	<ul style="list-style-type: none"> <li>• Ambient overtemperature protection</li> <li>• Ambient undertemperature protection</li> <li>• Internal overheating</li> <li>• Fan fault</li> <li>• AC input overvoltage, undervoltage, phase failure, or severe voltage imbalance</li> <li>• Slight or severe current imbalance</li> <li>• Incorrect or duplicate module hardware address</li> <li>• Output capacitance imbalance</li> <li>• Output relay alarm</li> <li>• Poor output connection</li> <li>• Communication failure between the charging module and external devices</li> <li>• Air filter blockage alarm</li> <li>• Output short circuit alarm</li> </ul>
	Blinking at 4 Hz	Manual setting mode of output parameters (dEG mode)
Fault indicator (red) 	Off	Normal: The charging module is normal.
	Steady on	<ul style="list-style-type: none"> <li>• Lockout due to output overvoltage</li> <li>• Lockout due to output short circuit</li> <li>• Communication failure between the primary side and the secondary side</li> <li>• Abnormal discharge circuit of the output capacitance</li> <li>• Unrecoverable no-output breakdown</li> </ul>

 NOTE

- If the charging module has no output due to mains failure (no AC input), the indicators are off.
- Indicators are not mutually exclusive. The three indicators can turn on at the same time if conditions are met.
- During software loading, the green, yellow, and red indicators turn on in turns. After the loading is complete, all indicators stop blinking.

## 2.4.3 Nixie Tube Display

The nixie tubes display the output voltage by default (**000** is displayed when there is no output). An error code is displayed when fault occurs.

**Table 2-5** Nixie tube description

Display	Description
Output voltage	<ul style="list-style-type: none"><li>• No decimal places. The precision is 1 V when the voltage ranges from 0 V to 999 V. There is no precision requirement when the voltage is greater than 999 V. The minimum displayed value is 000 V and the maximum displayed value is 999 V.</li><li>• Parameters can be set using buttons only in the setting mode but the settings are not saved upon power failure.</li></ul>
Output current	<ul style="list-style-type: none"><li>• The last digit is a decimal with the precision of 0.1 A. The minimum displayed value is 00.0 A and the maximum displayed value is 99.9 A.</li><li>• Parameters can be set using buttons only in the setting mode but the settings are not saved upon power failure.</li></ul>
Hardware address	<ul style="list-style-type: none"><li>• <b>Adr</b> is displayed by default. Hold down the button to enter the address display screen (static).</li><li>• On the setting screen (blinking), flip the first digit to enter the <b>CCC</b> screen. The default hardware address <b>127</b> (decimal) can be restored.</li><li>• After the hardware address is modified, the group number is restored to the default value.</li><li>• Parameters can be set using buttons and the settings are saved upon power failure.</li></ul>
Group number	<ul style="list-style-type: none"><li>• <b>GrP</b> is displayed by default. Hold down the button to enter the group number display screen (static).</li><li>• The group number is displayed in decimal format.</li><li>• Parameters can be set only under the company protocol. Setting is not supported under third-party protocol.</li><li>• Parameters can be set using buttons and the settings are saved upon power failure.</li></ul>
Error code	<ul style="list-style-type: none"><li>• The high-order nixie tube displays <b>E</b>, and the middle- and low-order nixie tubes display digits.</li><li>• Parameters cannot be set using buttons.</li></ul>
Startup/Shutdown	<ul style="list-style-type: none"><li>• <b>on</b>: startup; <b>off</b>: shutdown</li><li>• Parameters can be set using buttons only in the setting mode but the settings are not saved upon power failure.</li></ul>
Software version	<ul style="list-style-type: none"><li>• The value is displayed as digits.</li><li>• Parameters cannot be set using buttons.</li></ul>

Display	Description
Mode	<ul style="list-style-type: none"><li>• <b>Auo</b> is displayed by default in standard mode. The charging module works under the system monitoring command.</li><li>• <b>dEG</b> indicates the setting mode.<ol style="list-style-type: none"><li>1. The output voltage, output current, and startup/shutdown can be set only in this mode. The settings become invalid upon mode exiting.</li><li>2. The charging module can run properly without being connected to the system monitoring module.</li></ol></li><li>• The <b>Auo</b> and <b>dEG</b> modes can be switched using the buttons.</li></ul>
Status code	<ul style="list-style-type: none"><li>• The high-order nixie tube displays <b>H</b>, and the middle- and low-order nixie tubes display digits.</li><li>• Parameters cannot be set using buttons.</li></ul>

**Table 2-6** Status code mapping

Status Code	Status Description
H00	Default status
H01	Silent mode
H02	Input derating
H03	Temperature derating
H04	Air filter blocked
H05	Manual switching mode
H06	250 kbps baud rate

## 2.4.4 Button Operations

The buttons allow you to set the output voltage, output current, hardware address, and group number, and to start or shut down the charging module.

- Press the left button (for at least 0.25s) to turn the displayed screen or switch the high-, middle-, and low-order nixie tubes.
- Press the right button (for at least 0.25s) to turn the displayed screen or increase or decrease digits.
- Hold down the left or right button (for at least 3s) to enter the parameter setting state or save the current settings.

 **NOTE**

Hold down the left or right button to enter the parameter setting state. If no operation is performed within 60s, the setting state is automatically exited and the parameter settings are not saved.

## Setting the Output Voltage

- The output voltage can be set only after the mode is switched from Auo to dEG.
- The voltage settings of the charging module are not saved upon power failure.
- If the mode is switched from dEG to Auo, the charging module outputs according to the system monitoring command.

**Table 2-7** Procedure description

Procedure	Operation	Nixie Tube Display
1	Press the left or right button to switch to the mode display state.	Auo (static)
2	Hold down the left or right button to enter the setting state.	Auo (blinking)
3	Press the right button to switch to the dEG mode.	dEG (blinking)
4	Hold down the left or right button to enter the display state.	dEG (static)
5	Press the left or right button to switch to the output voltage display state.	Current output voltage (static)
6	Hold down the left or right button to enter the setting state.	Current output voltage (high-, middle-, or low-order nixie tube blinking)
7	Press the left button to switch between the high-, middle-, and low-order nixie tubes. Press the right button to adjust the value.	Adjusted output voltage (high-, middle-, or low-order nixie tube blinking)
8	Hold down the left or right button to save the settings.	Actual output voltage (static)

## Setting the Hardware Address

- To set the hardware address, you do not need to switch to the dEG mode.

- The hardware address settings of the charging module are saved upon power failure.

**Table 2-8** Procedure description

Procedure	Operation	Nixie Tube Display
1	Press the left or right button to switch to the hardware address display screen.	Adr (static)
2	Hold down the left or right button to enter the hardware address display screen.	Hardware address (decimal, static)
3	Hold down the left or right button to enter the hardware address setting screen.	High-, middle-, or low-order nixie tube blinking (decimal)
4	Press the left button to switch between the high-, middle-, and low-order nixie tubes. Press the right button to adjust the value.	Adjusted hardware address (high-, middle-, or low-order nixie tube blinking)
5	Hold down the left or right button to save the settings.	Hardware address (static). Then, the voltage display screen is displayed.

## Setting a Group No.

- To set the group number, you do not need to switch to the dEG mode.
- The group number settings of the charging module are saved upon power failure (only for the company protocol).

**Table 2-9** Procedure description

Procedure	Operation	Nixie Tube Display
1	Press the left or right button to switch to the group number display screen.	GrP (static)
2	Hold down the left or right button to enter the group number display screen.	Group number (decimal, static)
3	Hold down the left or right button to enter the group number setting screen.	Middle- or low-order nixie tube blinking (decimal)

Procedure	Operation	Nixie Tube Display
4	Press the left button to switch between the high-, middle-, and low-order nixie tubes. Press the right button to adjust the value.	Adjusted group number (middle- or low-order nixie tube blinking)
5	Hold down the left or right button to save the settings.	Group number (static). Then, the voltage display screen is displayed.

## 2.5 Module Ports

Figure 2-4 DC output and signal ports

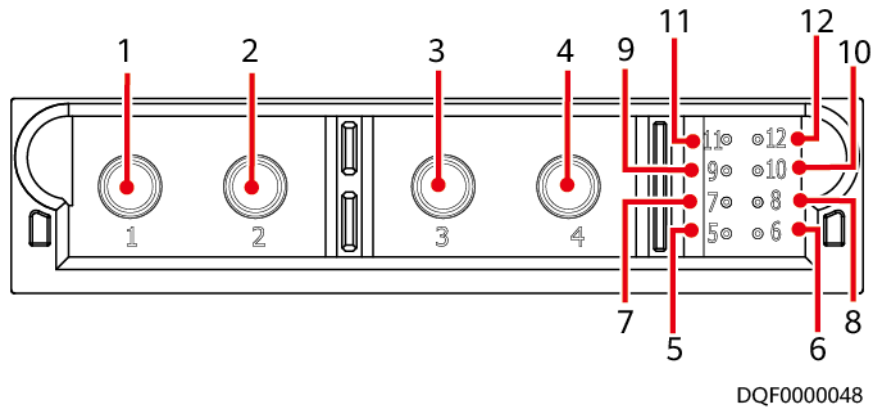


Table 2-10 Output port definition

Pin	Item	Function
1, 2	1000 V DC-	Negative output (pins 1 and 2 must be connected in parallel)
3, 4	1000 V DC+	Positive output (pins 3 and 4 must be connected in parallel)
5	CANBH	CAN high-level signal
6	CANBL	CAN low-level signal
7	CANBH	CAN high-level signal
8	CANBL	CAN low-level signal
9	CAN_GND	Signal ground
10	LINK_CHECK_OK	Insertion and removal control
11	URGENT_TURN_OFF+	Emergency shutdown+

Pin	Item	Function
12	URGENT_TURN_OFF-	Emergency shutdown-

Figure 2-5 AC input ports

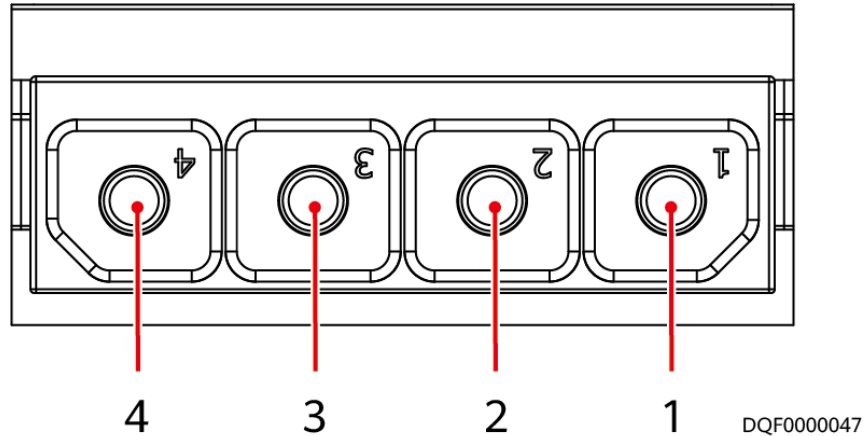


Table 2-11 Input port definition

Port	Item	Function
1	PE	Connects to the ground terminal in the system.
2	L1	AC input
3	L2	AC input
4	L3	AC input

## 2.6 Input and Output Connectors

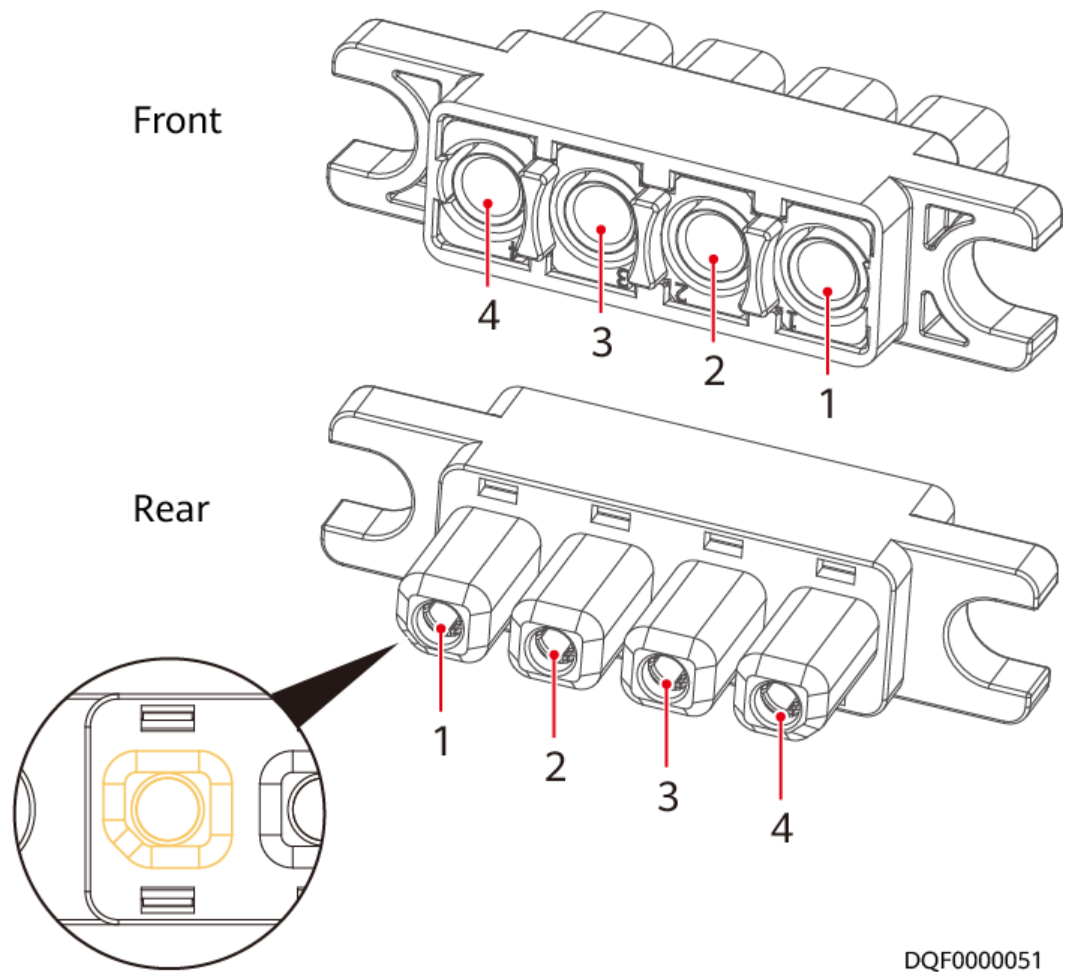
### 2.6.1 Input Connector

The model of the connector for AC input power cables is Huafeng DY98-02Z01. You need to check the connector dimensions and prepare it by yourself. Install the connector based on the requirements of the manufacturer.

#### NOTICE

Before connecting a cable, pay attention to the direction of the connector, especially the silkscreen on the front and the chamfer on the rear of the connector to ensure that the cable is correctly connected.

**Figure 2-6** Input connector



DQF0000051

**Table 2-12** Input connector definition

Port	Item	Function
1	PE	Connects to the ground terminal in the system.
2	L1	AC input
3	L2	AC input
4	L3	AC input

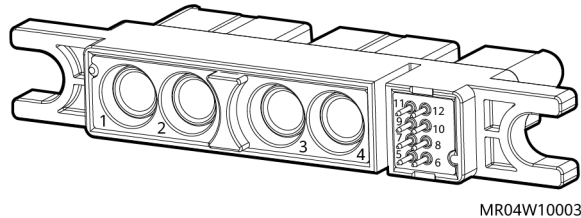
## 2.6.2 Output Connector

The DC output power cables can be connected in either of the following ways:

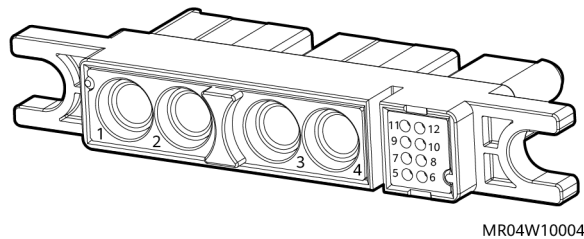
- Output connector with welded board on signal pins: The connector model is Huafeng DY98-01Z03. Install the external adapter board (provided by the customer) on the signal terminal, weld and secure the board, and then connect the communications cable.

- Output connector with crimped cables on signal pins: The connector model is Huafeng DY98-01Z02. Crimp the communications cable (prepared by the customer), connect the cable to the metal jack, and then insert the cable into the corresponding pin of the output connector.

**Figure 2-7** Output connector (DY98-01Z03, output connector with welded board on signal pins)



**Figure 2-8** Output connector (DY98-01Z02, output connector with crimped cables on signal pins)



**Table 2-13** Output connector definition

Pin	Item	Function
1, 2	1000 V DC-	Negative output (pins 1 and 2 must be connected in parallel)
3, 4	1000 V DC+	Positive output (pins 3 and 4 must be connected in parallel)
5	CANBH	CAN high-level signal
6	CANBL	CAN low-level signal
7	CANBH	CAN high-level signal
8	CANBL	CAN low-level signal
9	CAN_GND	Signal ground
10	LINK_CHECK_OK	Insertion and removal control
11	URGENT_TURN_OFF+	Emergency shutdown+
12	URGENT_TURN_OFF-	Emergency shutdown-

---

 **CAUTION**

Pin 9 and pin 10 of the DC output connector must be short-circuited. Otherwise, the charging module cannot be started.

---

# 3 Transportation and Storage

---

## Transportation

During transportation, the product must be securely placed in a packing case. The packing case must comply with related international standards and be printed with marks such as "Handle with care" and "Keep dry". The packing case must be protected against rains, snows, and mechanical impact during transportation.

## Storage

Unused products should be stored in packing cases and placed in a dry, well-ventilated warehouse where the temperature ranges from  $-10^{\circ}\text{C}$  to  $+40^{\circ}\text{C}$ , the relative humidity is not greater than 80%, and no corrosive gas exists. The product can be stored up to one year.

# 4 Installation

## NOTICE


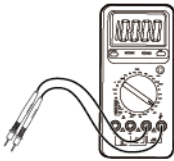
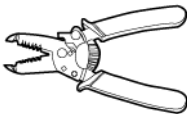

- In an indoor scenario, you are advised to power on the module within seven days after unpacking. If the module cannot be powered on in time, place it in a dry indoor environment without corrosive gases.
- In an outdoor scenario, you are advised to power on the module within 24 hours after unpacking. If the module cannot be powered on in time, place it in a dry indoor environment without corrosive gases.





## 4.1 Installation Preparations

### Checking Before Installation

- Before unpacking the charging module, check the outer packing materials for damage, such as holes and cracks, and check the model of the charging module. If any damage is found or the model is not what you required, do not unpack the charging module but contact the dealer as soon as possible.
- After unpacking the charging module, check whether the deliverables are intact and complete. If any item is missing or damaged, contact your dealer.

### Tools

			
Phillips insulated torque screwdriver	Multimeter	Wire stripper	Power cable cutter

 Heat gun	 Heat shrink tubing	 Protective gloves	 Protective shoes
---	---	---	---

## Cables

**⚠ CAUTION**

- Determine the temperature resistance level of the cable insulation materials based on the ambient temperature. Insulation materials of power cables and communications cables must be able to resist temperatures higher than or equal to 105°C.
- You need to prepare input connectors, output connectors, and cables by yourself.

**Table 4-1** Cable requirements

Cable	Recommended Specifications	Remarks
DC output power cable	Recommendation 1: flame-retardant cable with withstand voltage $\geq 1000$ V DC, temperature resistance $\geq 105^\circ\text{C}$ , and conductor cross-sectional area of $16\text{ mm}^2$ (example: ISO 6722, 1500 V DC, $125^\circ\text{C}$ , $16\text{ mm}^2$ , single-core unshielded cable)  Recommendation 2: flame-retardant cable with withstand voltage $\geq 1000$ V DC, temperature resistance $\geq 105^\circ\text{C}$ , and conductor cross-sectional area of 6 AWG (example: UL 10269, 6 AWG)	Two positive cables and two negative cables. If the cable surface temperature is higher than $90^\circ\text{C}$ , use high-temperature cables.

Cable	Recommended Specifications	Remarks
AC input power cable	<p>Recommendation 1: flame-retardant cable with withstand voltage <math>\geq 600</math> V AC, temperature resistance <math>\geq 105^{\circ}\text{C}</math>, and conductor cross-sectional area of <math>10\text{ mm}^2</math> (example: ISO 6722, 600 V AC, <math>125^{\circ}\text{C}</math>, <math>10\text{ mm}^2</math>, single-core unshielded cable)</p> <p>Recommendation 2: flame-retardant cable with withstand voltage <math>\geq 600</math> V AC, temperature resistance <math>\geq 105^{\circ}\text{C}</math>, and conductor cross-sectional area of 8 AWG (example: UL 3386, 8 AWG)</p>	If the cable surface temperature is higher than $90^{\circ}\text{C}$ , use high-temperature cables.
CAN communications cable (crimped with signal pins)	<p>Recommendation 1: twisted-pair shielded flame-retardant cable with withstand voltage <math>\geq 60</math> V DC, temperature resistance <math>\geq 105^{\circ}\text{C}</math>, and conductor cross-sectional area of <math>0.128\text{--}0.325\text{ mm}^2</math></p> <p>Recommendation 2: twisted-pair shielded flame-retardant cable with withstand voltage <math>\geq 60</math> V DC, temperature resistance <math>\geq 105^{\circ}\text{C}</math>, and conductor cross-sectional area of 26–22 AWG</p>	-

## 4.2 Installation Requirements

### NOTE

Application scope: charger or charging system

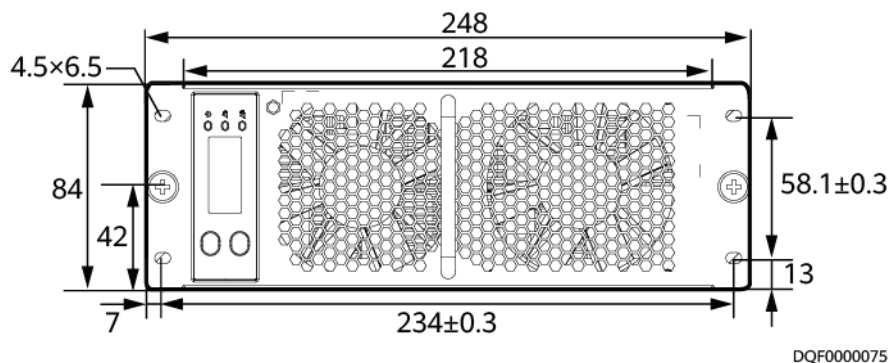
- The charger or charging system should meet the protection level requirements in section 10.5.1 of GB/T 18487.1-2015 and the environment protection requirements in section 7.3 of NB/T 33001-2018. The protection level of chargers should be at least IP32 (indoor) or IP54 (outdoor). Otherwise, the resulting functional exceptions or component damages are not covered under the warranty.
- Avoid using the product in offshore environments or outdoor onshore environments (with simple shielding measures) near heavy pollution sources. Otherwise, the product may be corroded or flooded. The resulting functional exceptions or component damages are not covered under the warranty. Pollution sources refer to the following areas:
  - Areas within 0.5 km of salt water such as the sea
  - Areas within 3 km of serious pollution sources, such as metallurgic plants, coal mines, and heat and power plants

- Areas within 2 km of medium pollution sources, such as chemical factories, rubber plants, and electroplating factories
- Areas within 1 km of light pollution sources, such as food factories, tanneries, and heating boilers
- When used in offshore environment, the module enclosure may be rusted or the service life of the entire system may be shortened. Therefore, exercise caution and consult the technical support when using modules in such environment. The area ranges from 0.5 km to 3.7 km away from salt water (such as the sea).
- The charger should be equipped with an air filter or dust-proof cotton to prevent large particles or catkins from blocking the air channel of the module. The resulting functional exceptions or component damages are beyond the warranty scope.
- It is recommended that the ventilation area for a single charging module be 13,800 mm<sup>2</sup>, and the minimum ventilation area be 10,800 mm<sup>2</sup>. The ventilation area of the system is calculated based on the number of modules. (The data is the heat dissipation area required for the charging module only.)
- It is recommended that the space reserved at the air intake vent and exhaust vent of the charging module be at least 40 mm and 85 mm respectively. The actual space depends on the system air channel.
- The installation environment must meet the environmental specifications. For details, see "Technical Specifications."

## 4.3 Installing a Charging Module

### Installation Clearances

Figure 4-1 Installation clearances (unit: mm)



### Installation Procedure

**⚠ CAUTION**

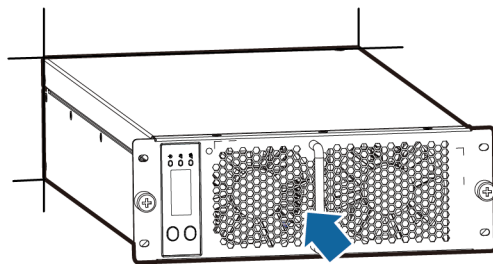
Do not keep the installed charging module in the standby or power-off state for an extended period.

 NOTE

- Ensure that all the mounting holes on the panel are secured by screws.
- Ensure that the nixie tubes are on the left side of the charging module during horizontal mounting. Ensure that the nixie tubes are on the upper side of the charging module during side mounting.
- The charging module supports horizontal-mounting and side-mounting installation. Select the installation mode based on the actual situation. The horizontal-mounting installation mode is recommended.

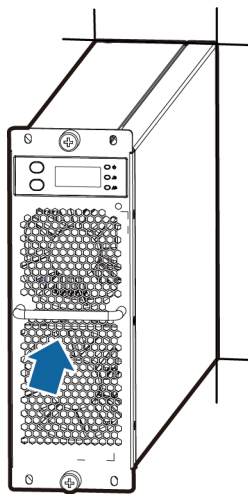
**Step 1** Slowly push the charging module into the slot.

**Figure 4-2** Installing a charging module (horizontal mounting)



MR04H10001

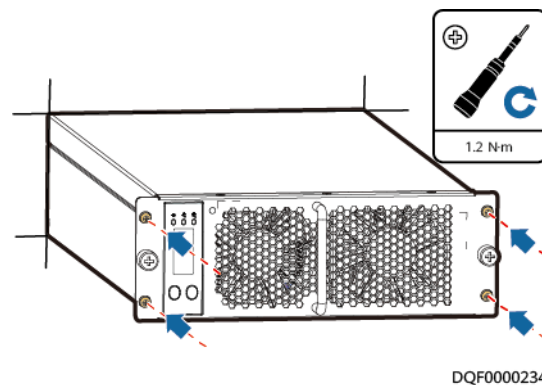
**Figure 4-3** Installing a charging module (side mounting)



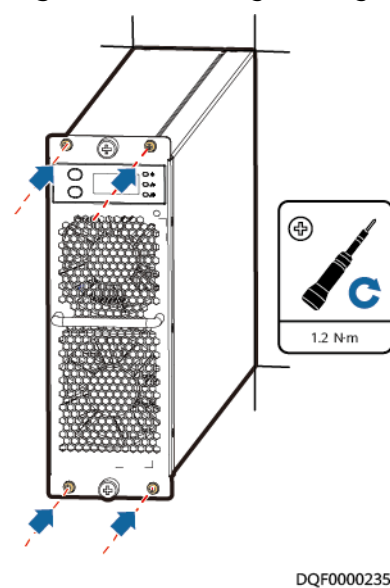
MR04H10002

**Step 2** Tighten the screws in the middle of the panel, and install and tighten the screws on the upper and lower parts of the panel.

**Figure 4-4** Securing a charging module (horizontal mounting)



**Figure 4-5** Securing a charging module (side mounting)



----End

## 4.4 Cable Connection

### 4.4.1 Connecting DC Output Power Cables

- The metal sockets are delivered with the DC output connector.
- Check whether the metal sockets are reliably crimped. The minimum pull-out force is 500 N for 6 AWG cables or cables with a cross-sectional area of 16 mm<sup>2</sup>.
- The front end of the heat shrink tubing should not exceed the scale on the metal socket. The outer diameter of the metal wire covered with the heat shrink tubing is less than or equal to 9.1 mm.

**NOTICE**

- You can perform emergency shutdown for the charging module by connecting pin 11 to the positive pole of the external power supply (9–15 V DC), and pin 12 to the negative pole.
- Pins 9 and 10 of the DC output connector must be short-circuited. Otherwise, the charging module cannot be started.

**Step 1** Connect the negative and positive DC output power cables.

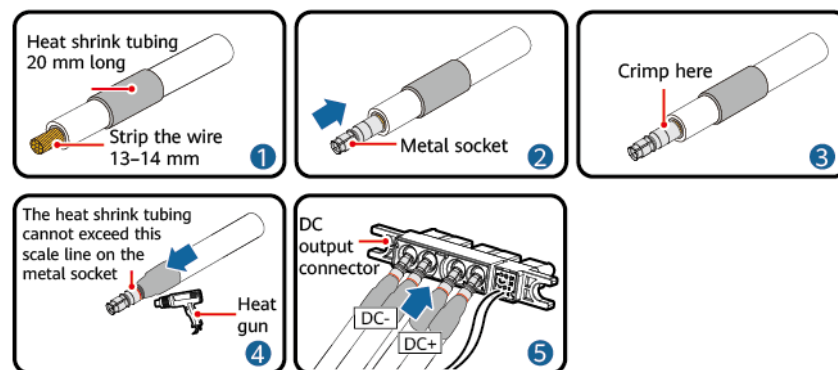
**Step 2** Connect cables.

- Output connector with welded board on signal pins: Install the external adapter board (prepared by the customer) on the signal terminals, weld and secure the board, and then connect the communications cables.
- Output connector with crimped cables on signal pins: Crimp the communications cables (prepared by the customer), connect the cables to the metal socket, and then insert the cables into the corresponding pins of the output connector.

**NOTE**

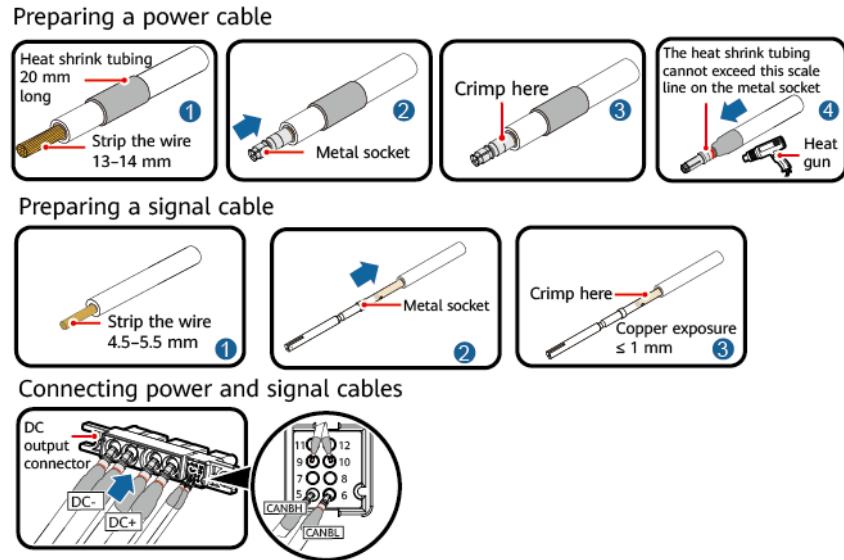
The following figure is for reference only and is not recommended for commercial use. To ensure reliability, it is recommended that cables be crimped by cable assembly companies or contact our sales personnel for recommend crimping solutions.

**Figure 4-6** Connecting DC output cables and signal cables (welded)



P000249

**Figure 4-7** Connecting DC output cables and signal cables (crimped)



P000250

----End

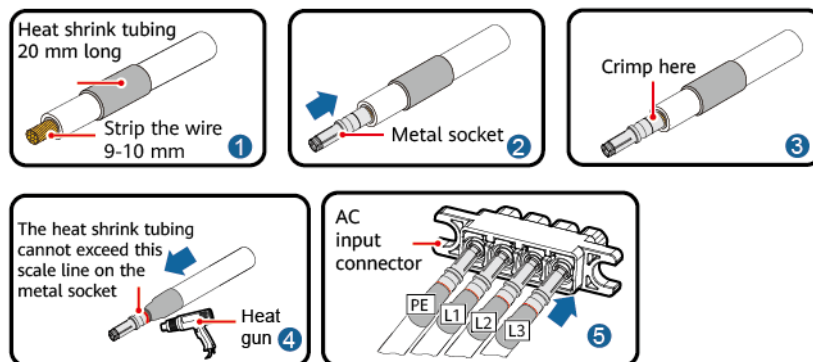
## 4.4.2 Connecting AC Input Power Cables

- The metal socket is delivered with the AC input connector.
- Check whether the metal socket is reliably crimped. The minimum pull-out force is 400 N for 8 AWG cables or cables with a cross-sectional area of 10 mm<sup>2</sup>.
- The front end of the heat shrink tubing should not exceed the scale on the metal socket. The outer diameter of the metal socket covered with the heat shrink tubing is less than or equal to 7.5 mm.

### NOTE

The following figure is for reference only and is not recommended for commercial use. To ensure reliability, it is recommended that cables be crimped by cable assembly companies or contact our sales personnel for recommend crimping solutions.

**Figure 4-8** Connecting AC input power cables



P000251

## 4.5 Powering On the Charging Module and Setting Parameters

- After the installation is complete, power on the charging module. Use a multimeter to check whether the voltage at the cabinet copper bar connected to the output connector of the charging module is within the normal range (200–506 V DC in low-voltage mode and 200–1000 V DC in high-voltage mode).
- Check that the power indicator on the charging module is steady on and the voltage displayed on the nixie tubes is the same as that measured by the multimeter.
- Set the hardware address of the charging module if grouping is required.

# 5 Maintenance

## 5.1 Routine Maintenance

To ensure that the charging module can operate properly for a long term, you are advised to perform routine maintenance on it as described in this chapter.

- The charging module is hot swappable and should be replaced if it is faulty.
- The air filter of the cabinet needs to be cleaned regularly to avoid dust buildup at the air inlet as dust can cause overheating inside the charging module.

## 5.2 Troubleshooting

- If the charging module is faulty, you can locate the fault based on the error code displayed on the nixie tubes.
- If no error code is displayed, locate the fault based on the indicator status.

**Table 5-1** List of error codes

Error Code	Symptom	Measure
E00	No fault	N/A
	Other protection	1. Exchange the slot of the faulty module with that of a normal module. If the fault occurs only in the original slot, the slot is abnormal and needs to be handled. 2. Exchange the slot of the faulty module with that of a normal module. If the fault occurs again after the slot exchange, replace the faulty module or contact the technical support.
	Other faults	


Error Code	Symptom	Measure
E01	Module overtemperature and undertemperature protection	<ol style="list-style-type: none"><li>1. Check whether the ambient temperature of the charging module is too high or too low. If yes, rectify the fault.</li><li>2. Check whether the air intake vent of the charging module is blocked. If yes, rectify the fault.</li><li>3. Exchange the slot of the faulty module with that of a normal module. If the fault occurs only in the original slot, the slot is abnormal and needs to be handled.</li><li>4. Exchange the slot of the faulty module with that of a normal module. If the fault occurs again after the slot exchange, replace the faulty module or contact the technical support.</li></ol>
E02	Input overvoltage, undervoltage, or phase failure	<ol style="list-style-type: none"><li>1. Check whether the input voltage of the charging module is normal. If not, rectify the fault.</li><li>2. Check whether the input cables and circuit breakers of the charging module are normal. If not, rectify the fault.</li><li>3. Exchange the slot of the faulty module with that of a normal module. If the fault occurs only in the original slot, the slot is abnormal and needs to be handled.</li><li>4. Exchange the slot of the faulty module with that of a normal module. If the fault occurs again after the slot exchange, replace the faulty module or contact the technical support.</li></ol>
E03	Short circuit protection	<ol style="list-style-type: none"><li>1. Check whether the output of the charging module is short-circuited. If yes, rectify the fault.</li><li>2. Exchange the slot of the faulty module with that of a normal module. If the fault occurs only in the original slot, the slot is abnormal and needs to be handled.</li><li>3. Exchange the slot of the faulty module with that of a normal module. If the fault occurs again after the slot exchange, replace the faulty module or contact the technical support.</li></ol>


Error Code	Symptom	Measure
E04	Fan fault	<ol style="list-style-type: none"> <li>1. Check whether the fan is stuck by foreign objects. If yes, rectify the fault.</li> <li>2. Exchange the slot of the faulty module with that of a normal module. If the fault occurs only in the original slot, the slot is abnormal and needs to be handled.</li> <li>3. Exchange the slot of the faulty module with that of a normal module. If the fault occurs again after the slot exchange, replace the faulty module or contact the technical support.</li> </ol>
E05	Duplicate hardware address	<ol style="list-style-type: none"> <li>1. Reset the hardware address and group number of the module.</li> <li>2. Exchange the slot of the faulty module with that of a normal module. If the fault occurs only in the original slot, the slot is abnormal and needs to be handled.</li> <li>3. Exchange the slot of the faulty module with that of a normal module. If the fault occurs again after the slot exchange, replace the faulty module or contact the technical support.</li> </ol>
E06	Output overvoltage	<ol style="list-style-type: none"> <li>1. Exchange the slot of the faulty module with that of a normal module. If the fault occurs only in the original slot, the slot is abnormal and needs to be handled.</li> <li>2. Exchange the slot of the faulty module with that of a normal module. If the fault occurs again after the slot exchange, replace the faulty module or contact the technical support.</li> </ol>

Error Code	Symptom	Measure
E07	Current sharing alarm	<ol style="list-style-type: none"><li>1. Check whether the preset voltages of different charging modules are the same. If not, rectify the fault.</li><li>2. Check whether the output cables and output circuit breakers of the charging module are properly connected. If not, rectify the fault.</li><li>3. Exchange the slot of the faulty module with that of a normal module. If the fault occurs only in the original slot, the slot is abnormal and needs to be handled.</li><li>4. Exchange the slot of the faulty module with that of a normal module. If the fault occurs again after the slot exchange, replace the faulty module or contact the technical support.</li></ol>
E08	CAN communication failure	<ol style="list-style-type: none"><li>1. Check the CAN communications cable connection (whether the cable is reversely connected and whether the connection is secure). Check whether the termination resistors are connected as required (connect one 120-ohm resistor in parallel at the remote end and local end, respectively). If any exception occurs, handle it.</li><li>2. Check whether the address and group number set for the module match those delivered by the monitoring module. If they do not match, rectify them.</li><li>3. Exchange the slot of the faulty module with that of a normal module. If the fault occurs only in the original slot, the slot is abnormal and needs to be handled.</li><li>4. Exchange the slot of the faulty module with that of a normal module. If the fault occurs again after the slot exchange, replace the faulty module or contact the technical support.</li></ol>


Error Code	Symptom	Measure
E09	Poor connection	<ol style="list-style-type: none"><li>1. Check whether the charging module is properly connected. If not, rectify the fault.</li><li>2. Check whether pin 9 and pin 10 of the output terminal are short-circuited. If not, short-circuit them.</li><li>3. Exchange the slot of the faulty module with that of a normal module. If the fault occurs only in the original slot, the slot is abnormal and needs to be handled.</li><li>4. Exchange the slot of the faulty module with that of a normal module. If the fault occurs again after the slot exchange, replace the faulty module or contact the technical support.</li></ol>

**Table 5-2** Troubleshooting based on charging module indicators

Indicator	Status	Description	Troubleshooting
Power indicator (green) 	Off	No AC input	<ol style="list-style-type: none"><li>1. Check whether the AC input is normal. If yes, replace the module. If no, rectify faults (such as short circuit) on the charger and the AC part of the module, and then check the AC input.</li><li>2. Replace the faulty module.</li></ol>

Indicator	Status	Description	Troubleshooting
Alarm indicator (yellow) 	Always on	Ambient overtemperature protection	<ol style="list-style-type: none"> <li>1. Check whether the ambient temperature of the charging module is too high or too low and whether the air intake vent is blocked. If yes, rectify the fault.</li> <li>2. Check whether the input voltage of the charging module is normal and whether the input cables and input circuit breakers are properly connected. If not, rectify the fault.</li> <li>3. Check whether the preset output voltages of different charging modules are the same and whether the output cables and output circuit breakers are properly connected. If not, rectify the fault.</li> <li>4. Check whether the charging module hardware address is duplicate. If yes, rectify the fault.</li> <li>5. Check whether the charging module is properly connected. If not, rectify the fault.</li> <li>6. Check whether the fan of the charging module is stuck by foreign objects. If yes, rectify the fault.</li> <li>7. Exchange the slot of the faulty module with that of a normal module. If the fault occurs only in the original slot, the slot is abnormal and needs to be handled.</li> <li>8. Exchange the slot of the faulty module with that of a normal module. If the fault occurs again after the slot exchange, replace the faulty module or contact the technical support.</li> </ol>
		Ambient undertemperature protection	
		Internal overheating	
		Fan fault	
		AC input overvoltage, undervoltage, phase failure, or severe voltage imbalance	
		Slight or severe current imbalance	
		Incorrect or duplicate module hardware address	
		Output capacitance imbalance	
		Output relay alarm	
		Poor output connection	
Air filter blockage alarm			

Indicator	Status	Description	Troubleshooting
		Communication failure between the charging module and external devices	<ol style="list-style-type: none"><li>1. Check the CAN communications cable connection (whether the cable is reversely connected and whether the connection is secure). Check whether the termination resistors are connected as required (connect one 120-ohm resistor in parallel at the remote end and local end, respectively). If any exception occurs, handle it.</li><li>2. Check whether the address and group number set for the module match those delivered by the monitoring module. If they do not match, rectify them.</li><li>3. Exchange the slot of the faulty module with that of a normal module. If the fault occurs only in the original slot, the slot is abnormal and needs to be handled.</li><li>4. Exchange the slot of the faulty module with that of a normal module. If the fault occurs again after the slot exchange, replace the faulty module or contact the technical support.</li></ol>
		Output short circuit alarm	<ol style="list-style-type: none"><li>1. Check whether the output port of the charging module is short-circuited.</li><li>2. Replace the faulty module.</li></ol>

Indicator	Status	Description	Troubleshooting
Fault indicator (red) 	Always on	Lockout due to output overvoltage	1. Check whether the air channel of the charging module is seriously blocked. If yes, rectify the fault. 2. Check whether the output of the charging module is short-circuited. If yes, rectify the fault. 3. Exchange the slot of the faulty module with that of a normal module. If the fault occurs only in the original slot, the slot is abnormal and needs to be handled. 4. Exchange the slot of the faulty module with that of a normal module. If the fault occurs again after the slot exchange, replace the faulty module or contact the technical support.
		Lockout due to output short circuit	
		Communication failure between the primary side and the secondary side	
		Abnormal discharge circuit of the output capacitance	
		Unrecoverable no-output breakdown	
Note: If the alarm persists, contact the technical support.			

## 5.3 Replacement

Replace the product if an unrecoverable fault occurs.

### Prerequisites

- You have obtained a Phillips insulated torque screwdriver, protective gloves, and protective shoes.
- The new charging module is intact.

#### NOTE

Before replacing the faulty module, record its hardware address and group number to ensure the consistency after the replacement.

### Procedure

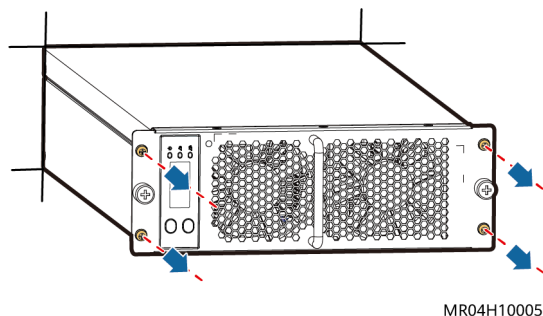
**Step 1** Take out the charging module.

#### DANGER

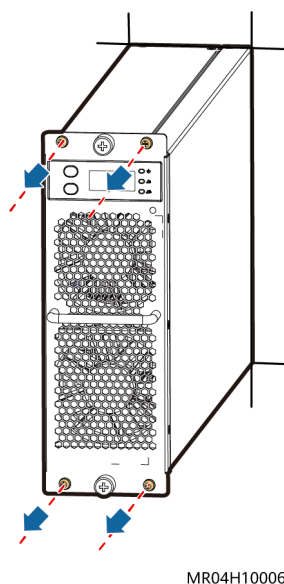
- Do not touch the terminals at the rear of the charging module.
- Avoid scalding due to module overheating.

1. Loosen the screws on the left side of the panel and the screws in the mounting ear on the right.

**Figure 5-1** Loosening screws (horizontal mounting)

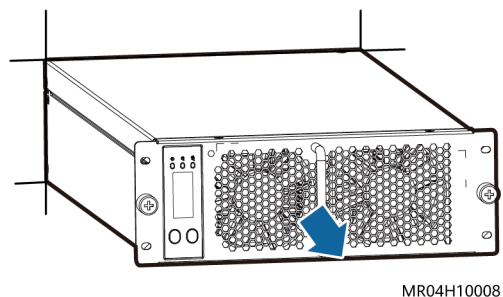


**Figure 5-2** Loosening screws (side mounting)

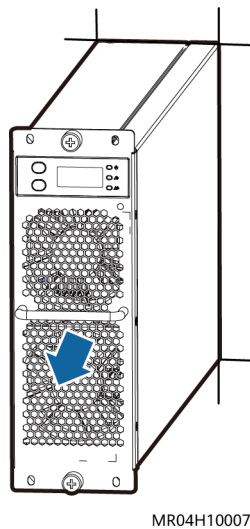


2. Loosen the screws in the middle of the panel and remove the charging module.

**Figure 5-3** Removing a charging module (horizontal mounting)



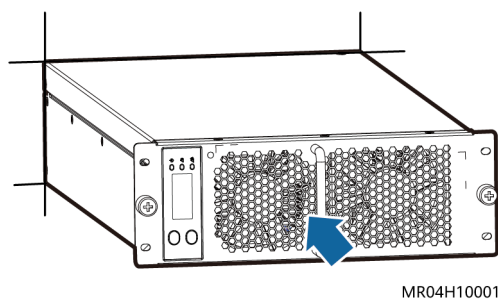
**Figure 5-4** Removing a charging module (side mounting)



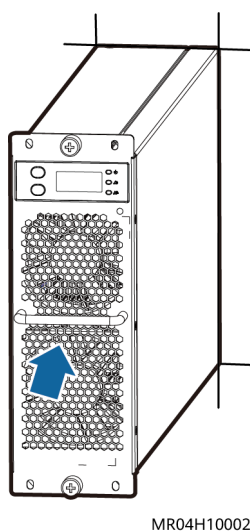
**Step 2** Install the new charging module.

1. Slowly push the charging module into the slot.

**Figure 5-5** Installing a charging module (horizontal mounting)

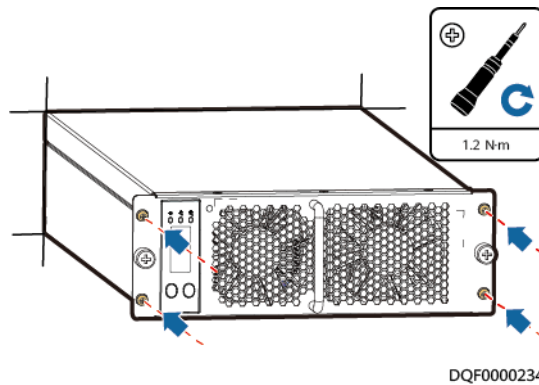


**Figure 5-6** Installing a charging module (side mounting)

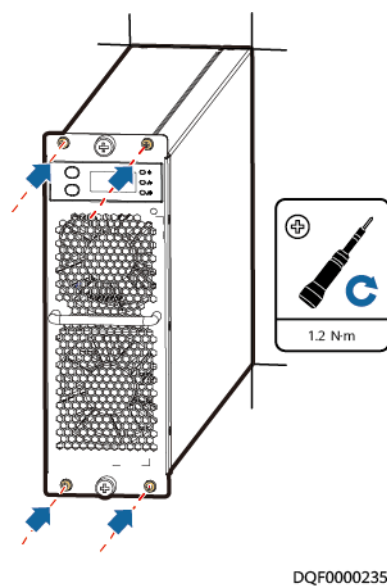


2. Tighten the screws in the middle of the panel, and install and tighten the screws on the upper and lower parts of the panel and the screws on the mounting ear.

**Figure 5-7** Securing a charging module (horizontal mounting)



**Figure 5-8** Securing a charging module (side mounting)



**Step 3** After the installation is complete, the system monitoring module sends a startup command to the charging module. Check that the green indicator on the charging module turns on to ensure normal running.

**Step 4** Set the hardware address of the charging module if grouping is required, as described in "Button Operations."

----End

# 6 Technical Specifications

## 6.1 Structure

Table 6-1 Structure

Item	Specifications
Dimensions (H x W x D)	<ul style="list-style-type: none"><li>• 84 mm x 218 mm x 458 mm (without packaging)</li><li>• 142 mm x 350 mm x 605 mm (with packaging)</li></ul>
Weight	<ul style="list-style-type: none"><li>• ≤ 15 kg (without packaging)</li><li>• ≤ 16 kg (with packaging)</li></ul>
IP rating	IP20

## 6.2 Environment

Table 6-2 Environment

Item	Specifications
Operating temperature	-35°C to +75°C (The output power is derated when the temperature is higher than 55°C under the rated output voltage.)
Relative humidity	5%–95% RH (non-condensing)

## 6.3 Input

**Table 6-3** Input

Item	Specifications
Input voltage	260–485 V AC (rated voltage: 380 V AC)
Voltage system	Three-phase four-wire (3W+PE)
Frequency	40–70 Hz; rated frequency: 50 Hz/60 Hz
Input current	≤ 60 A
Power factor	≥ 0.98 (load ≥ 50%)
THD	≤ 5% (load ratio ≥ 50%)

## 6.4 Output

**Table 6-4** Output

Item	Specifications
Output voltage	<ul style="list-style-type: none"><li>Low-voltage mode: 200–506 V DC</li><li>High-voltage mode: 200–1000 V DC (Performance indicators are not assessed if the voltage is below 400 V in high-voltage mode.)</li></ul>
Rated output current	High-voltage mode: 30 A
Output power	Rated power: 30 kW <ul style="list-style-type: none"><li>When the voltage ranges from the power conversion point to 260 V AC, the output is linearly derated from full load to half load.</li><li>When the voltage ranges from the power conversion point to 485 V AC, the charging module outputs at full load.</li></ul> (Power conversion point range: 303–323 V AC)
Output current limiting range	Maximum: 100 A
Soft start time	3–8s
Hibernation function	Supported
Standby power consumption	≤ 9.3 W (tested average power consumption under 380 V AC rated input voltage at 25°C)

Item	Specifications
Hot swapping	Supported
Communications bus protocol	CAN

## 6.5 Protection

Table 6-5 Protection

Item	Specifications
Input undervoltage protection	$\leq 260$ V AC (line voltage)
Input overvoltage protection	487–510 V AC (line voltage)
Input three-phase imbalance positive offset protection (line voltage)	Minimum: 15% (The input three-phase imbalance positive offset recovery threshold is less than or equal to 11%.)
Input three-phase imbalance negative offset protection (line voltage)	Maximum: -13% (The input three-phase imbalance negative offset recovery threshold is greater than or equal to -9%.)
Output overvoltage protection threshold	<ul style="list-style-type: none"><li>High-voltage mode: 1020–1050 V DC</li><li>Low-voltage mode: 510–525 V DC</li></ul>
Overtemperature protection	Shutdown protection is triggered when the ambient temperature exceeds $78\pm 5^{\circ}\text{C}$ . Non-automatic recovery
Undertemperature protection	Shutdown protection is triggered when the ambient temperature is lower than $-40\pm 5^{\circ}\text{C}$ . Non-automatic recovery

## 6.6 Other Characteristics

Table 6-6 EMC/surge protection

Item	Specifications
EMC	<ul style="list-style-type: none"><li>NB/T 33008.1-2018</li><li>NB/T 33001-2018</li><li>GB/T 18487.2-2017</li></ul>
Surge protection	$\pm 5$ kA

**Table 6-7** Reliability

Item	Specifications
Mean time between failures (MTBF)	500,000 hours (40°C, rated input)

## 6.7 Characteristic Curves

**Figure 6-1** Efficiency curve ( $V_{out}$  @ 750 V DC)

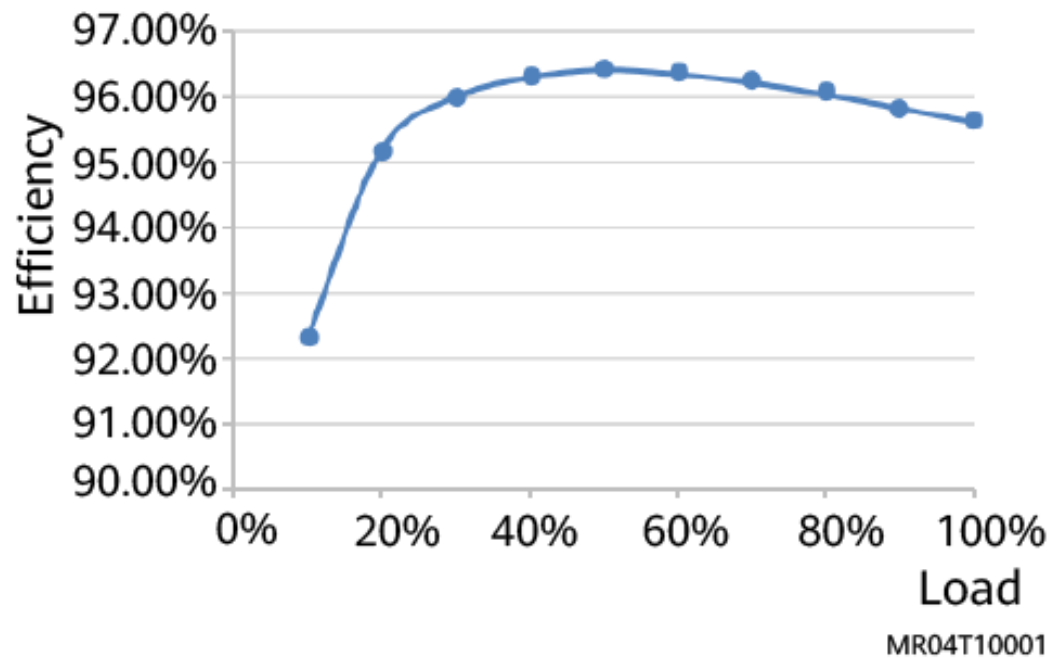


Figure 6-2 Output characteristic curve

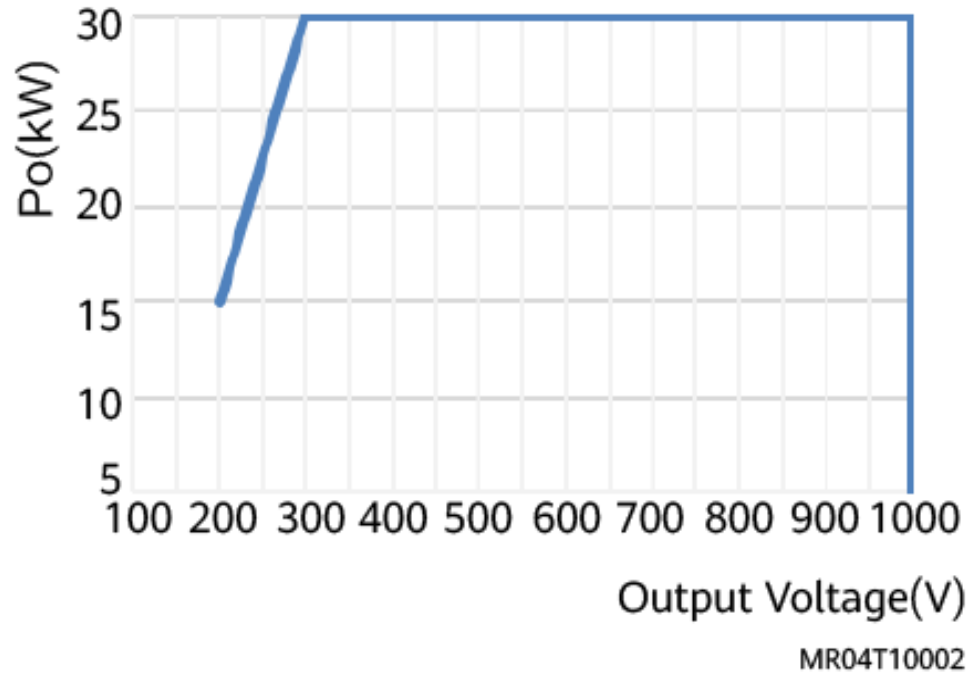
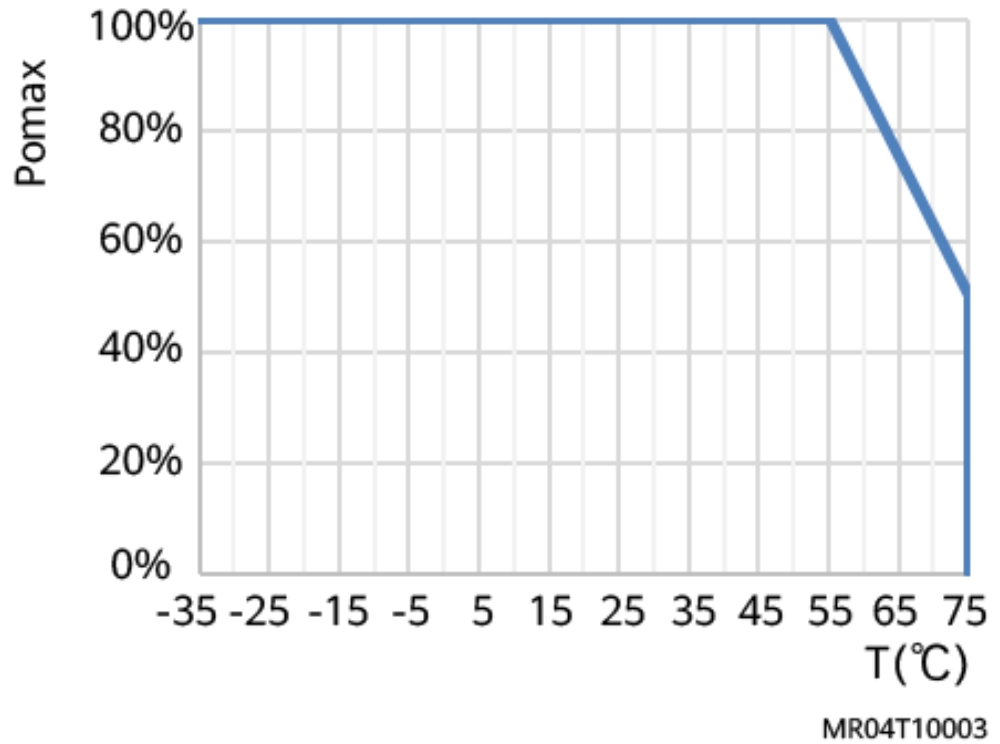


Figure 6-3 Temperature derating curve



# A Acronyms and Abbreviations

---

## C

**CAN**

controller area network

## M

**MTBF**

mean time between failures

## T

**THD**

total harmonic distortion